

 **spigodoor**<sup>®</sup>

**SP**

# Spigo - laar

Spigodoor, división de Spigogroup especialmente diseñada para ofrecer soluciones en puertas técnicas. Dispone de una amplia oferta de productos técnicos multifuncionales que garantizan performances específicas.

Spigodoor, division of Spigogroup especially designed to offer solution in technical doors. It is available of a wide offer of multipurpose technical products which guarantee specific performances.





## Acabados

### Finishes

Spigodoor le ofrece todo un mundo de posibilidades y contrastes en acabados y materiales. Podrá elegir el acabado que desee para que la fabricación de sus puertas combine a la perfección en su proyecto.

Spigodoor provides you a world full of possibilities and contrasts in finishes and materials. The customer will be able to choose the desired finish in order to the production of the doors will perfectly combine.

#### DM PARA PINTAR DM FOR PAINTING



Suministro de puerta Spigodoor en DM para pintar, facilitando al cliente la posibilidad de terminar el proceso final según sus necesidades.

The provision of Spigodoor doors in DM for painting. This option gives the customer the chance to complete the final process depending on customers' needs.

#### RECHAPADO VARNISHED VENEER



Suministro de puerta Spigodoor en una amplia variedad de rechapados (roble, haya, cerezo, maple...), que dotan de una categoría y calidad exclusiva que sólo puede dar la madera natural.

The provision of Spigodoor doors with a wide variety of varnished veneers (oak, beech, cherry, maple, among others) which provide high quality and category that can just give the natural wood.

#### LACADOS LACQUERS



Suministro de puerta Spigodoor en una amplia variedad de lacados, adaptados a cualquier referencia de las cartas PANTONE, RAL o NCS.

The provision of Spigodoor doors in a wide variety of lacquers, adapted to any reference of PANTONE, RAL o NCS cards.

#### HPL LAMINADO LAMINATED HPL



Suministro de puerta Spigodoor en HPL de aplacados de laminados fenólicos de alta presión, para los clientes que deseen perdurabilidad y una alta resistencia a impactos y rayaduras.

The provision of Spigodoor doors in laminated HPL is for the customers who desire perdurability and a high antibacterial, moisture and temperature changes resistance.



*Posibilidad de fabricar en cualquier otro acabado deseado, según proyecto y/o según indicaciones de la dirección facultativa.*

*There is possibility to produce in any desired finish, according to project or indications of site management.*

[www.spigogroup.com](http://www.spigogroup.com)





## Serie Basic

### Basic Serie

Spigodoor a través de su Serie Basic le garantiza una amplia gama de performances exclusivas que responden a las tendencias de la arquitectura moderna y que mejor se adaptan al espacio y estilo que esté buscando.

Spigodoor through its Basic Serie ensures a wide range of exclusive performances which are a response to the trends of modern architecture and which are adaptable to space and searched style.

La Serie Basic de Spigodoor presenta una línea de puertas especiales desarrolladas para suministrar y ofrecer soluciones en puertas técnicas innovadoras capaces de superar cualquier expectativa. Estos productos certificados tienen la posibilidad de fabricarse con diferentes opciones de interior y cantos a elegir, aportando los más altos estándares de diseño y funcionalidad.

Basic Serie of Spigodoor presents a new line of special doors developed to supply and offer solutions in innovative technical doors which are capable of overcoming any expectation. These approved products have the possibility to manufacture with different choices of interior and edges, giving the highest design and functionality standards.

#### OPCIONES DE INTERIOR INTERIOR OPTIONS

##### MODELO BASIC BOARD BASIC BOARD MODEL

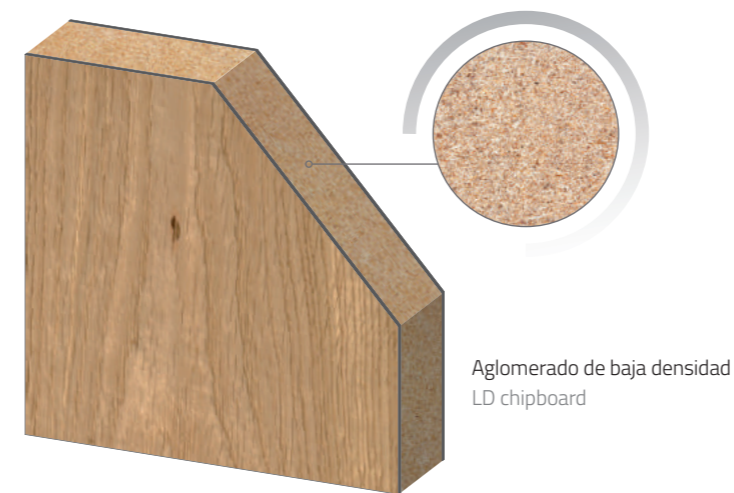

Aglomerado de baja densidad  
LD chipboard

##### MODELO BASIC LIGHT BASIC LIGHT MODEL

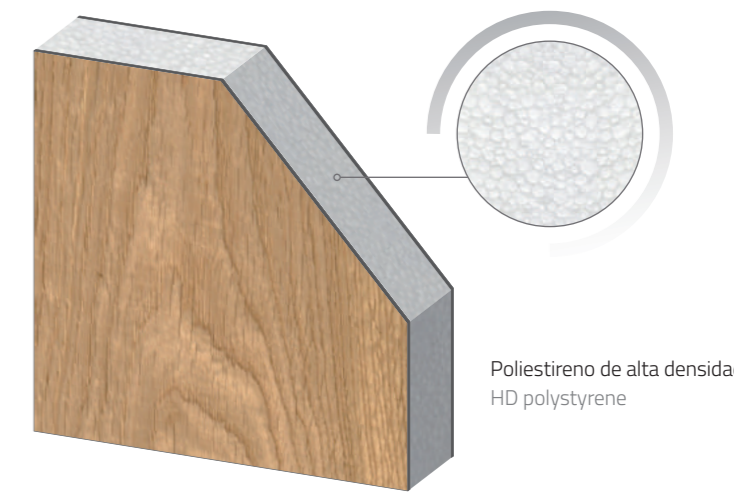

Poliestireno de alta densidad  
HD polystyrene

#### OPCIONES DE CANTO EDGE CHOICES



Contrachapado Plywood



PVC PVC



Compacto Compact



Macizo Solid





## Serie Sound

### Sound Serie

Spigodoor a través de su Serie Sound le garantiza la fabricación de las mejores puertas isofónicas del mercado para su instalación en locales dónde el requisito de aislamiento acústico es preponderante.

Spigodoor through its Sound Serie guarantees manufacturing of the best sound doors on the market to their installation in locals in which acoustic insulation is a dominant requisite.

La Serie Sound de Spigodoor presenta una línea de puertas isofónicas desarrolladas para proporcionar niveles de insonorización desde 32 dB hasta 42 dB. Esta clase de productos están especialmente indicados para su instalación en distintos ámbitos como hoteles, hospitales, escuelas, teatros... en función de los niveles de ruido que se quiera aislar.

Sound Serie of Spigodoor presents a line of sound doors developed to provide soundproofing levels from 32dB to 42dB. This type of products is especially designed to the installation in different areas such as hotels, hospitals, schools and theatres, among others in accordance with the quantity of noise which the customer needs to isolate.

#### NIVELES DE AISLAMIENTO INSULATION LEVELS



Gracias al diseño personalizado y la fabricación a medida de todas nuestras puertas, podemos suministrarlas con unas dimensiones y acabado final acordes al proyecto acústico y las necesidades de cada cliente.

Thanks to personalized design and custome-made of all our doors; Spigogroup is capable of supplying with final dimensions and finish according to acoustic project and customer's needs.





sp

## Serie Fire

### Fire Serie

Spigodoor a través de su Serie Fire le garantiza la solución idónea tanto estética como técnicamente para conseguir la puerta técnica perfecta que ejerza de barrera ante el fuego, retrasando el avance del incendio.

Spigodoor through its Fire Serie secures you the ideal solution both aesthetically and technically, to get a perfect technical door which applies a barrier against the fire retarding the progress of conflagration.

La Serie Fire de Spigodoor presenta una línea de puertas cortafuegos desarrolladas para proporcionar unos niveles de seguridad contra incendios conforme la normativa de seguridad vigente. Este tipo de puertas proporciona el tiempo necesario para controlar la evacuación del local y la intervención de los equipos de extinción y rescate.

Fire Serie of Spigodoor presents a line of fire doors developed to provide security levels against firefighting according to prevailing legislation. This type of door affords the time needed to manage the total local evacuation and the intervention of rescue and extinction team.

#### MODELO RF30; EI1 30-C5 MODEL FR30; EI1 30-C5

El modelo de puerta RF30 (EI1 30-C5), alcanza una resistencia al fuego de 30 minutos según la norma UNE-EN 13501-2; 2009+A1.

The model FR30 (EI 30-C5) is a block which reaches a fire resistance for 30 minutes in accordance with UNE-EN 13501-2; 2009+A1.

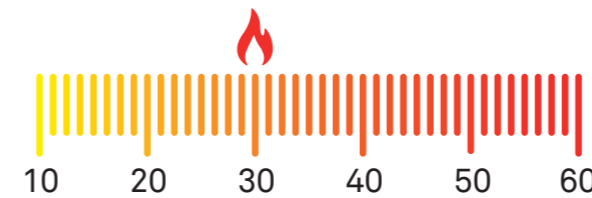

#### MODELO RF60; EI1 60-C5 MODEL FR60; EI1 60-C5

El modelo de puerta RF60 (EI1 60-C5), alcanza una resistencia al fuego de 60 minutos según la norma UNE-EN 13501-2; 2009+A1.

The model FR60 (EI 60-C5) is a block which reaches a fire resistance for 60 minutes in accordance with UNE-EN 13501-2; 2009+A1.

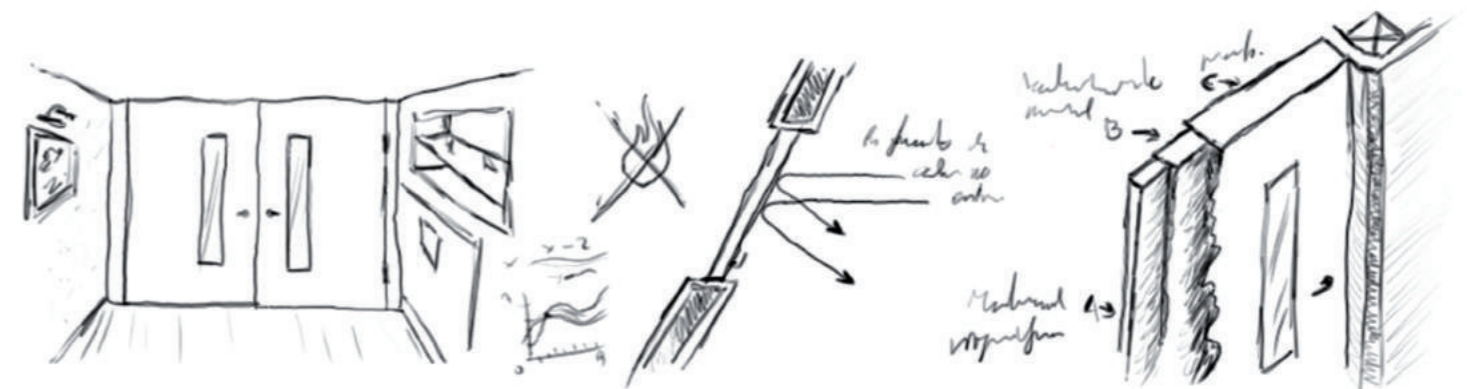
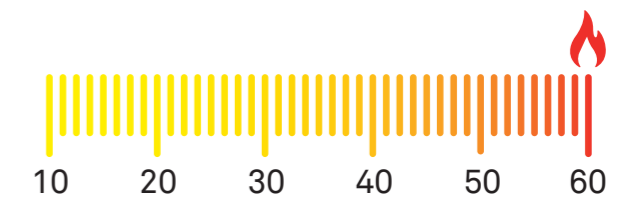



## Sistemas Especiales

### Special Systems

Spigodoor cuenta con la posibilidad de implementar sistemas especiales como el antipinzadados, panelado o enrasado, que garanticen la satisfacción completa en la elección de su puerta técnica.

Spigodoor counts on the possibility of implementing special systems such as fingers guard system, panelled or flush which guarantee the final end user complete satisfaction.

#### PUERTA ENRASADA RUSH DOOR

El sistema especial de puerta enrasada es la solución que permite instalar una puerta totalmente camuflada a la vista e integrada en la pared. Una vez instalada, gracias a su plena integración muestra todas sus cualidades, dando mayor énfasis a los detalles constructivos del entorno en el que se encuentra.

The special system of rush door is the solution that allows installing a fully camouflaged door. Furthermore, this system gets to integrate the door into the wall and the environment until it retreated. Once installed, thanks to totally integration, these doors show all their qualities, giving greater emphasis to constructive details of its context.

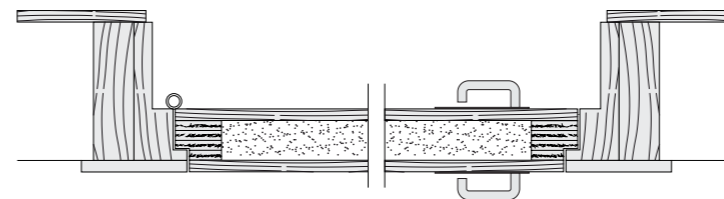

#### PUERTA PANELADA PANELLED DOOR

El sistema especial de puerta panelada es la solución que permite instalar una hoja a la que se adhiere un panelado como elemento decorativo que permite personalizar cualquier espacio arquitectónico y representa un acabado de apariencia verdaderamente profesional integrado en conjunto.

The special system of panelled door is the solution that allows installing a leaf in which a panel is adhered as a decorative element. This panel allows the customer to personalize any architectonic space and shows a finish with professional-looking and included as a whole.

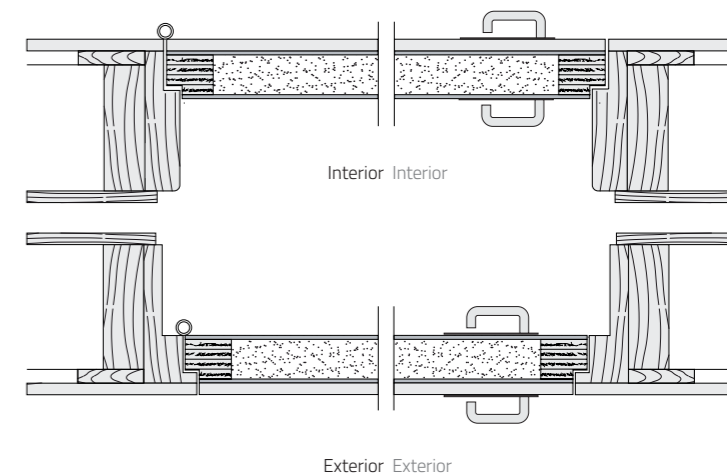

#### PUERTA ANTIPINZAMIENTO FINGER GUARD SYSTEM

El sistema especial de puerta antipinzamiento es la solución especialmente concebida para instalaciones donde vayan a convivir o transitar niños. La solución se basa en la colocación de juntas de goma a ambos lados de la hoja con la finalidad de evitar el pinzamiento y/o pillado de dedos.

The special system of finger guard doors is the solution particularly conceived to facilities where go to coincide or transit children. The solution is based on collocating rubber joints on both sides of leaf in order to avoid fingers pinches.





## Complementos

### Complements

Spigodoor le ofrece un amplio abanico de soluciones en accesorios y complementos únicos para incorporar en su pedido de puertas y conseguir unos estándares de calidad, diseño y seguridad inigualables.

Spigodoor gives a wide range of solutions in unique accessories and complements to incorporate in your order of technical doors and in this way, the customer will be able to get unsurpassed standards of quality, design and security.



*Todos los kits estándar se suministran con su pernio y picaporte correspondiente.*

*All standard kits are supplied with corresponding hinge and knocker.*

[www.spigogroup.com](http://www.spigogroup.com)



# Características Characteristics

## DM PARA PINTAR DM FOR PAINTING

Suministrado para que el cliente termine el proceso final según sus necesidades.

Technical doors are supplied to the customer so as to finish the final process.

DM  
DM

## HPL LAMINADO LAMINATED HPL

Aplacados de laminados fenólicos de alta presión.

High density phenolic laminated.

## RECHAPADO VARNISHED VENEER

Maple  
Maple

Haya  
Beech

Cerezo  
Cherry

Roble  
Oak

Otros acabados en madera natural, consultar. If others finishes are required, please consult us.

## LACADO LACQUERS

Capacidad de adaptar nuestros paneles a cualquier referencia de las cartas PANTONE, RAL y NCS.

Spigogroup has the capacity of adapting the panels to any reference of PANTONE, RAL or NCS card.

ELEMENTOS INCLUIDOS EN EL KIT ESTÁNDAR		ELEMENTS INCLUDED IN THE STANDARD KIT	
	BASIC	SOUND	FIRE
Hoja Sheet	Según indicaciones According to your requirements		
Cerco/Botana Frame	Hasta 120 mm Up to 120 mm		
Jambas/Tapetas Jamb	90x10 mm		
Pernios Hinges	SI YES		Homologados Approved
Picaporte Knocker	SI YES		Cerradura homolog. sin cilindro Approved lock without cylinder

## CRITERIO DE MANOS HAND CRITERIA

Para definir la mano de una puerta se adopta el criterio establecido en la norma IRAM 11505 parte 1, donde la mano izquierda abre con un movimiento de rotación antihorario y la mano derecha abre con un movimiento de rotación horaria.

To define the hand of a door, an established rule in IRAM 11505 Part 1 regulation is adopted, where the left hand opens with a counterclockwise rotation movement and right hand opens with clockwise rotation movement.

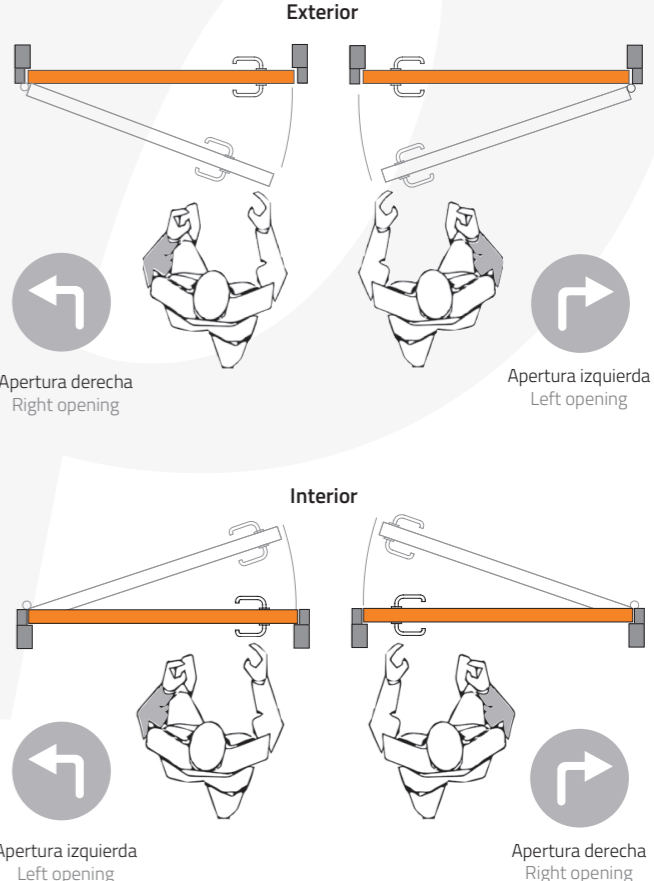

# Medidas Sizes

## MEDIDAS ESTÁNDAR STANDARD SIZES

MEDIDA HOJA LEAF DIMENSION		HUECO OBRA CONSTRUCTION OPENING SIZE	
ANCHO WIDTH	ALTO HEIGHT	ANCHO WIDTH	ALTO HEIGHT
425	2030	475	2065
525	2030	575	2065
625	2030	675	2065
725	2030	775	2065
825	2030	875	2065
925	2030	975	2065

Medidas en milímetros. Dimension in millimetres.

## MEDICIÓN MEASURING

A la hora de realizar el pedido de una puerta es importante conocer bien cómo se toman las medidas de los huecos, así como todos los datos necesarios para dar al fabricante y que no haya ningún problema. Desde Spigogroup, aconsejamos tomar las medidas de los huecos en obra una vez ejecutados (no sobre el plano), uno a uno y dar la medida real y exacta (las holguras las damos nosotros).

When ordering of a door, it is important to know very well how to take the opening measures and all necessary data to give manufacturer and in this way, there will not be any problem. From Spigogroup, we advise on taking the measures on site, not taking them on the drawings and give the real and exact dimension (We give the clearances).

Siga estos sencillos pasos antes de hacer el pedido de su puerta  
Follow these easy steps when ordering the doors



### ANCHURA WIDTH

Mide la distancia del interior del premarco (A).  
Measure the interior distance of subframe (A).

### ESPESOR THICKNESS

Mide el espesor del tabique o pared (B).  
Measure the thickness of partition or wall (B).

### ALTURA HEIGHT

Mide la distancia entre la parte horizontal del premarco y el suelo (C).  
Measure the distance between subframe horizontal part and floor (C).

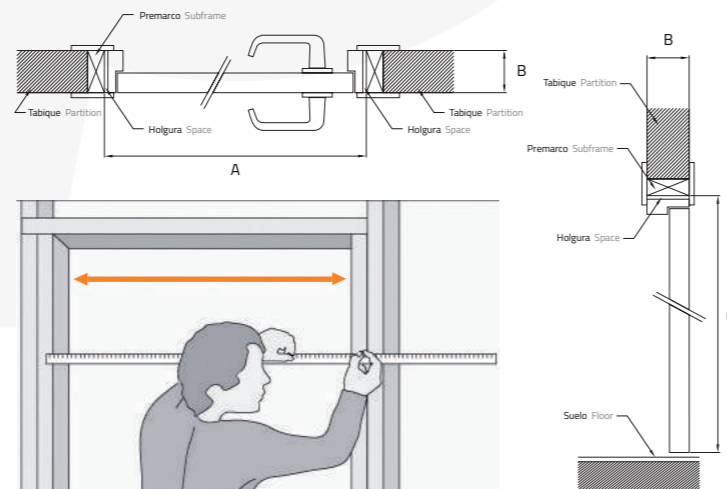

# Plazos de fabricación Production deadlines

En Spigodoor encontrará la solución más completa en el mercado de puertas técnicas en un tiempo récord. Contamos con una alta flexibilidad a la hora de fabricación de puertas especiales a medida y le garantizamos la posibilidad de un servicio express cuyos plazos de entrega para cualquier puerta especial resultan inmejorables.

Spigodoor will provide you the most complete solution on the technical door market in record time. We count on high flexibility in developing custom special doors and ensure you the possibility of express service whose delivery terms to any type of door are excellent.

## PLAZOS DE FABRICACIÓN PRODUCTION DEADLINES



DM para pintar DM for painting	15 días days
Lacados Lacquers	20-25 días days
HPL Laminated HPL	30-40 días days
Rechapado Varnished Veneer	30-40 días days

⚠ Plazo exacto a la formalización del pedido.  
Production deadlines will be given in a precise way, when the purchase order will be accepted.



Asesoramiento y trato personalizado  
Personalized service and assessment



Alta flexibilidad en plazos de entrega  
High flexibility in delivery terms



Puertas a medida según las necesidades  
Customized doors as required



Adaptabilidad a las nuevas tendencias  
Adaptability in new trends



Agilidad en los procesos de fabricación  
More efficient manufacturing processes



Garantía de calidad  
Quality assurance

Entrega a partir de 2 semanas  
Delivery from two weeks



# SERVICIO EXPRESS

# Serie Basic Basic Serie

## Basic Board

Aglomerado de baja densidad  
LD chipboard

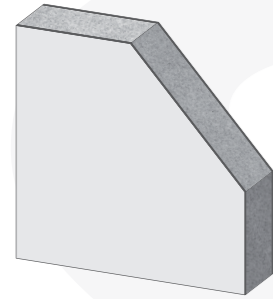

## TIPOS DE CANTOS TYPES OF EDGES

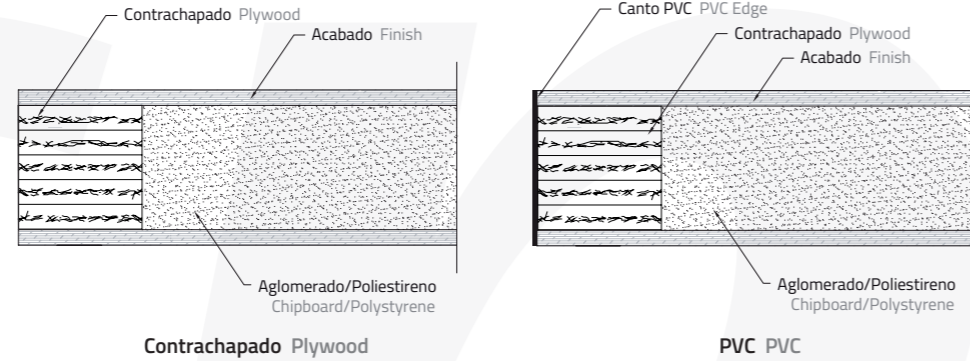

## Basic Light

Poliestireno de alta densidad  
HD polystyrene

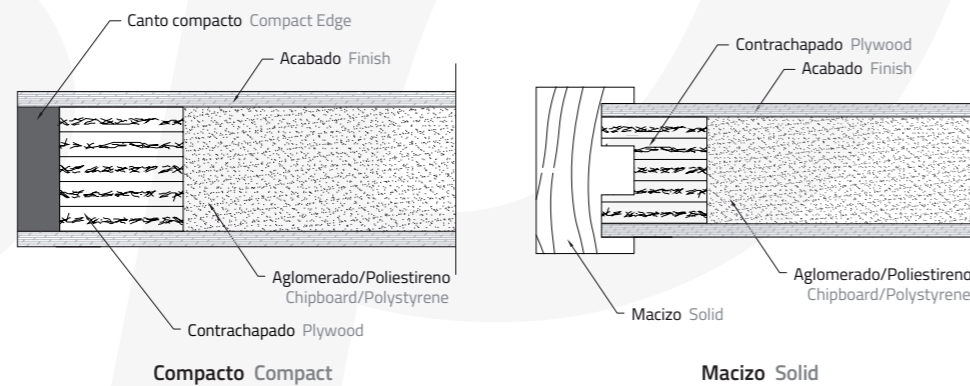
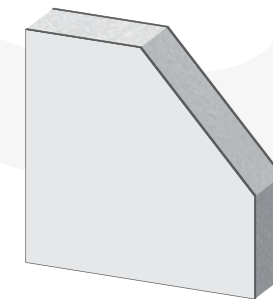

La Serie Basic de Spigodoor permite completar su puerta a medida eligiendo entre marco de madera o aluminio según sus necesidades y los requerimientos técnicos del proyecto.

Basic Serie of Spigodoor allows completing the customized door choosing between wooden and aluminum frame as required and technical requirements of project.

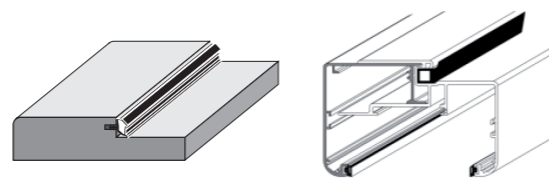

Marco de madera  
Wood frame

Marco de aluminio  
Aluminum frame

# Serie Fire Fire Serie

## RF30; E11 30-C5 FR30; E11 30-C5

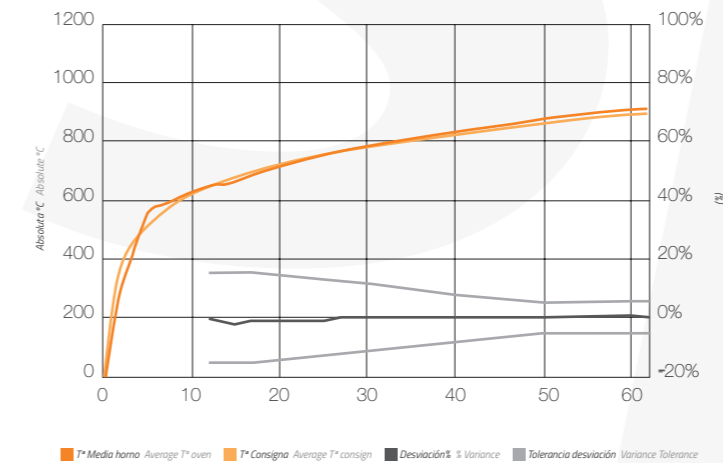
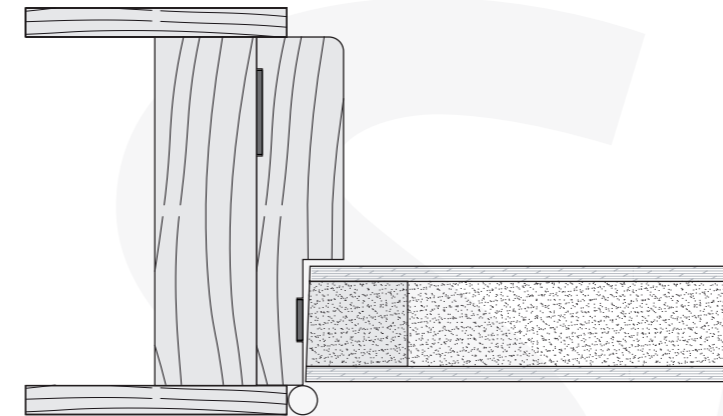

### RESULTADO OBTENIDOS RESULTS OBTAINED

S/UNE-EN: 1634-1:2010	E11 30-C5
S/UNE-EN: 14600:2006	
S/UNE-EN 1191:2000	

Resistencia al fuego Fire resistance. | Resistencia durabilidad y autocierra Durability and self-closing.

## RF60; E11 60-C5 FR60; E11 60-C5

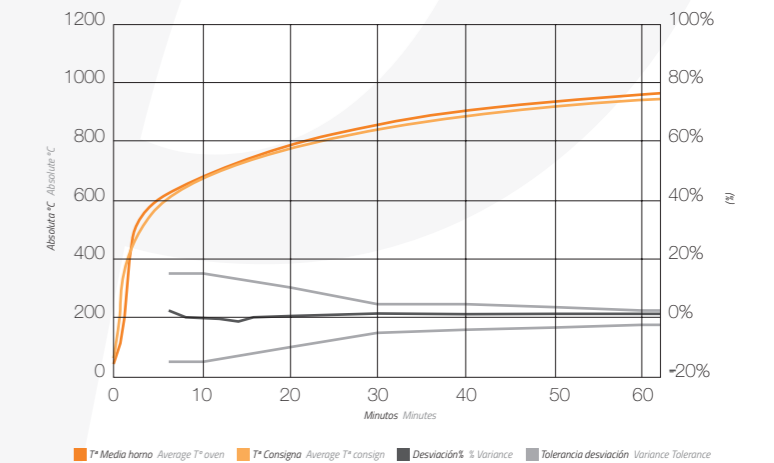
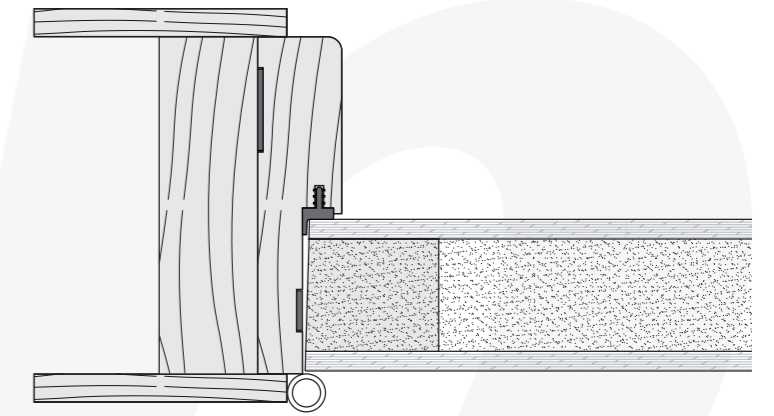

### RESULTADO OBTENIDOS RESULTS OBTAINED

S/UNE-EN: 1634-1:2010	E11 60-C5
S/UNE-EN: 14600:2006	
S/UNE-EN 1191:2000	

Resistencia al fuego Fire resistance. | Resistencia durabilidad y autocierra Durability and self-closing.

# Serie Sound Sound Serie

ISOFÓNICA 32 dB SOUNDPROOF 32 dB

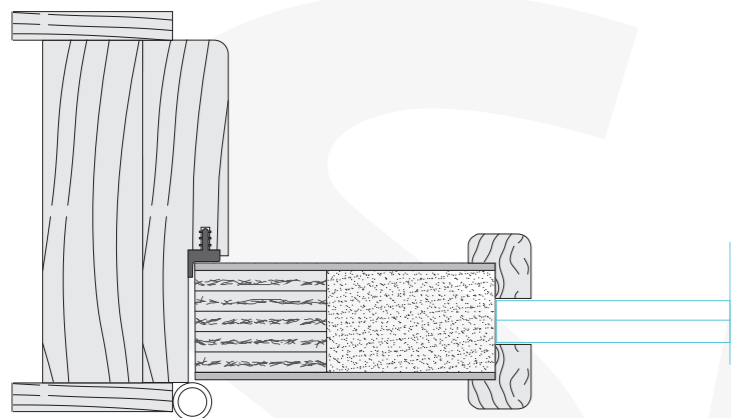

Homologación puerta con vidrio laminar incluido en conjunto.  
Type approval of door with laminated glass included as a whole

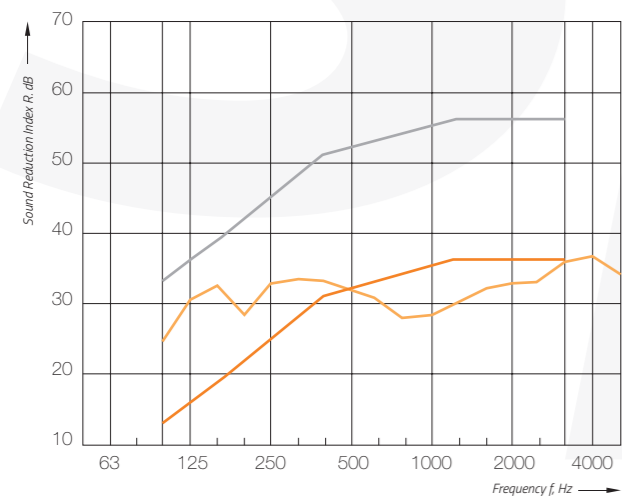

RESULTADO OBTENIDOS RESULTS OBTAINED

S/UNE-EN ISO 10140-2:2011  
S/ISO 717-1

RW (C; CTR) = 32 (0;-1) dB

ISOFÓNICA 34 dB SOUNDPROOF 34 dB

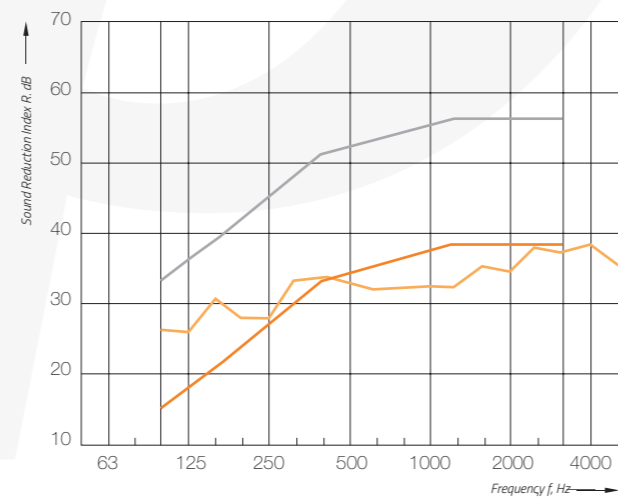
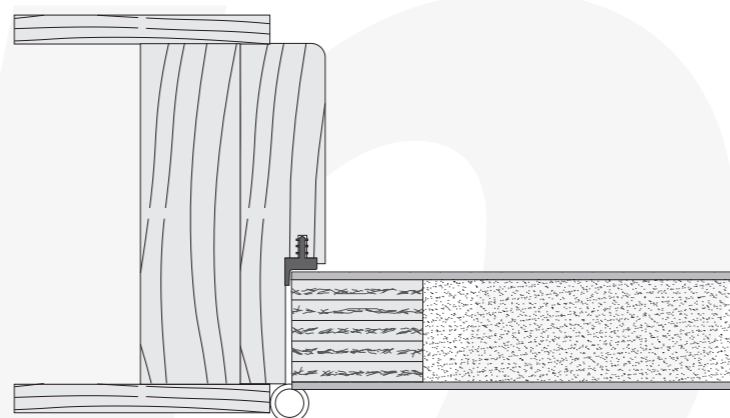

RESULTADO OBTENIDOS RESULTS OBTAINED

S/UNE-EN ISO 10140-2:2011  
S/ISO 717-1

RW (C; CTR) = 34 (-1;-2) dB

ISOFÓNICA 38 dB SOUNDPROOF 38 dB

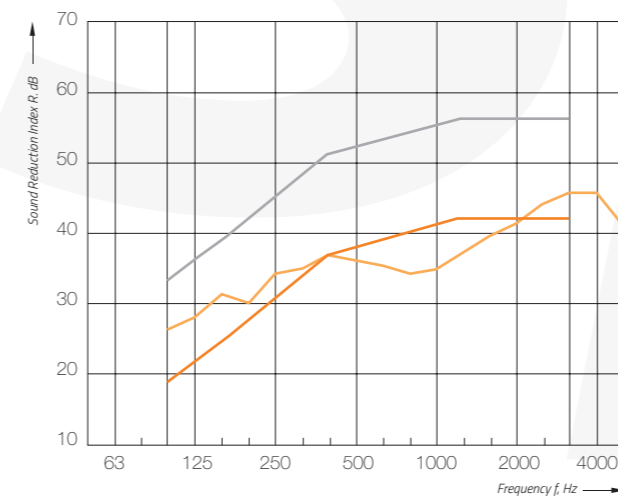
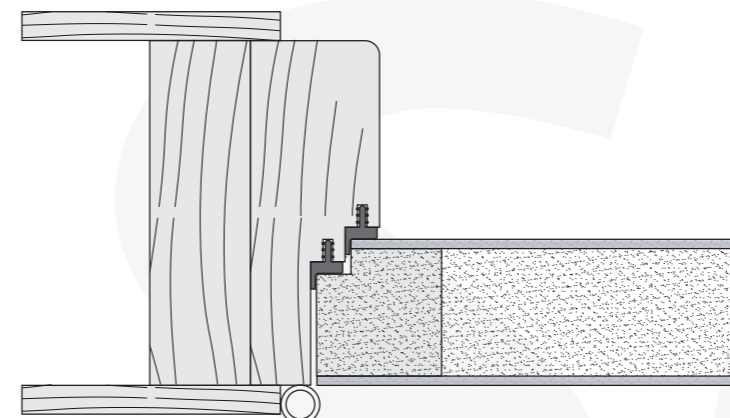

RESULTADO OBTENIDOS RESULTS OBTAINED

S/UNE-EN ISO 10140-2:2011  
S/ISO 717-1

RW (C; CTR) = 38 (-1;-2) dB

ISOFÓNICA 42 dB SOUNDPROOF 42 dB

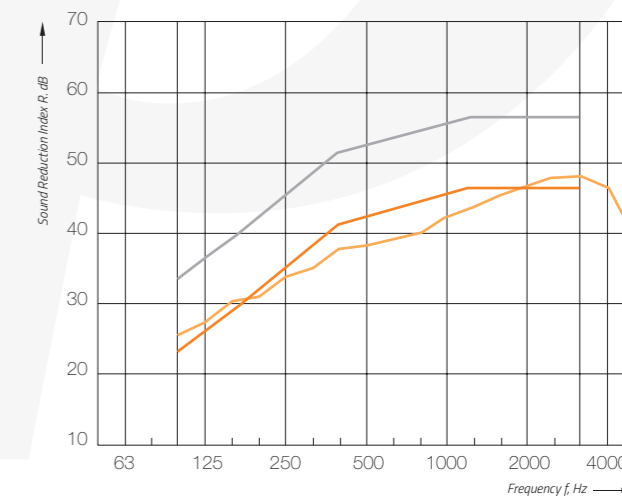
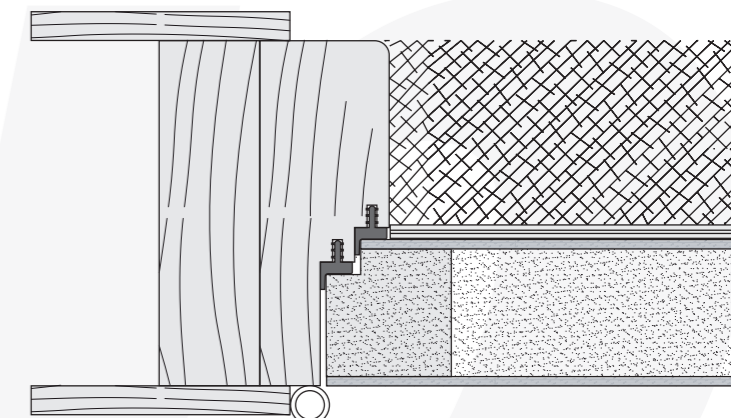

RESULTADO OBTENIDOS RESULTS OBTAINED

S/UNE-EN ISO 10140-2:2011  
S/ISO 717-1

RW (C; CTR) = 42 (-1;-3) dB



# Sistemas especiales Special Systems

## ANTIPINZAMIENTO FINGER GUARD SYSTEM

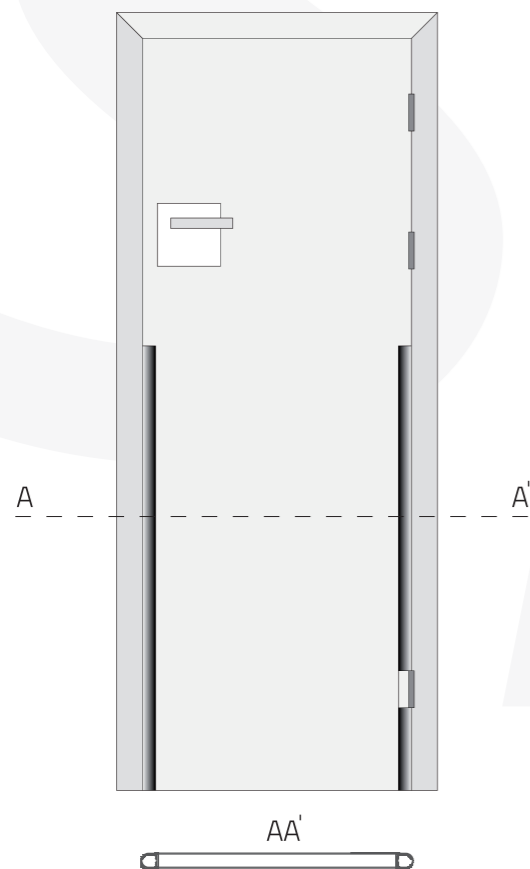



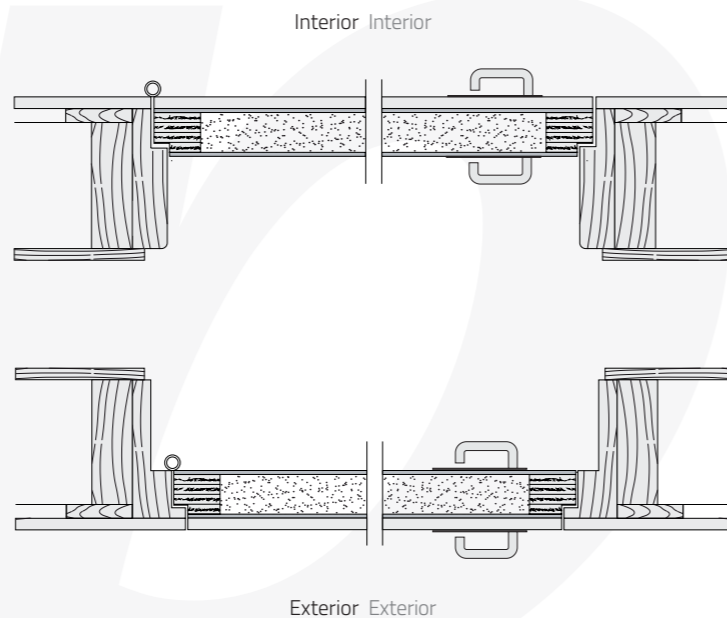



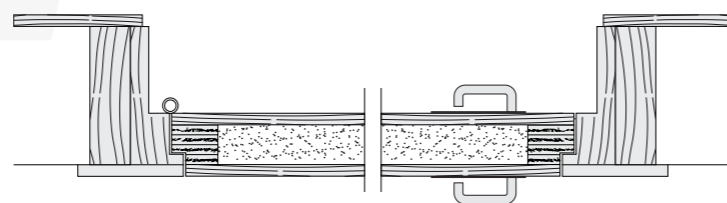

## PUERTA PANELADA PANELLED DOOR



## PUERTA ENRASADA RUSH DOOR







# Áreas de aplicación Application areas

- |  |   |  |  |
|--|---|--|--|
|  <b>Centros de enseñanza</b><br>Aulas<br>Colegios<br>Guarderías<br>Universidades<br>Academias | <b>Educational Establishments</b><br>Rooms<br>Schools<br>Nurseries<br>Universities<br>Academies |  <b>Restauración</b><br>Bares<br>Restaurantes<br>Hoteles  | <b>Restoration</b><br>Bars<br>Restaurants<br>Hotels  |
|  <b>Usos múltiples</b><br>Salas de conferencias<br>Auditorios<br>Bibliotecas                | <b>Multiple applications</b><br>Conference rooms<br>Auditoriums<br>Libraries                    |  <b>Salud</b><br>Hospitales<br>Centros de salud         | <b>Health</b><br>Hospitals<br>Health centres         |
|  <b>Aeropuertos</b>   | <b>Airports</b>   |  <b>Centros de ocio</b><br>Cines<br>Centros comerciales | <b>Leisure Centre</b><br>Cinemas<br>Shopping centres |
|  <b>Estudios de radio y TV</b>  | <b>Radio &amp; TV Studio</b>  | Centros culturales<br>Teatros  | Cultural centres<br>Theatres                         |
|  <b>Iglesias</b>  | <b>Churches</b>   | Salas de conciertos<br>Ludotecas   | Concert halls<br>Play centre                         |
|  <b>Edificios públicos</b>  | <b>Public buildings</b>   |  |  |

# Prescripción Prescription





Elegir **Spigodoor** representa tener la garantía de una calidad de servicio irreprochable. Profesionalidad, conocimientos técnicos y escucha para resolver lo mejor posible cualquier consulta constituyen nuestros principios fundamentales.

Pero elegir **Spigodoor** también significa beneficiarse de las numerosas ventajas de una firma con personalidad única e importante reputación:

-  Todas nuestras puertas combinan diseño y funcionalidad, que contribuyen a crear mejores condiciones y crear buenos ambientes interiores.
-  Las características y el embalaje de cada performance ofrece las mejores condiciones para el transporte, la manipulación y el almacenamiento.
-  Las medidas de las puertas son estándar. Pero el sistema de puertas Spigodoor permite fabricarlas en cualquier medida especial bajo previa consulta y con un incremento sobre el precio estándar.
-  Están de conformidad con todas las certificaciones y normas vigentes que avalan la calidad de nuestros productos.
-  Cuentan con la mejor relación calidad-precio en un plazo inmejorable. Los acabados son perfectos y el resultado es impecable.

Choosing **Spigodoor** means to have the guarantee of an irreproachable quality service. Professionality, technical knowledges and listening to solve in the best way any request are our main principles.

But choosing **Spigodoor** also means to benefit from the advantages of a firm with unique personality and considerable reputation:

-  All Spigodoor products combine design and functionality, contribute to create better conditions and good interior circles.
-  The characteristics and packaging of all our products offer the best conditions for the transport, manipulation and storage.
-  Spigodoor products have standard dimensions. However, the system of Spigodoor products leads to produce in any special dimension on request and with a price increase.
-  Spigodoor technical doors accomplish all the certifications, homologations and existing rules which guarantee the quality of our products.
-  Spigodoor products count on the price-quality ratio in an unbeatable deadline. The finishes are perfect and the result incredible.

Para facilitar la elaboración de proyectos y la selección de nuestra gama de soluciones en puertas técnicas **Spigodoor**, ponemos a disposición de nuestros clientes la siguiente herramienta que apoyará su decisión de prescribir Spigogroup. Les permitirá localizar fácilmente la información que desean e incorporarla a sus presupuestos y planos.

To facilitate the elaboration of projects and the selection of our range of technical doors **Spigodoor**, Spigogroup put at customers' disposal the following tool which support with their decision to prescribe Spigogroup.



ACCESO A PRESTO ACCESS TO PRESTO





- Información técnica Technical info.
- Planos Drawings
- Medidas Sizes
- Modelos Models
- Características Characteristics

## EJEMPLO TEXTO MEMORIA PROYECTO EXAMPLE TEXT MEMORY PROJECT

*Suministro y colocación de bloque de puerta Spigodoor Serie Sound 32 dB homologada de una hoja, de medida normalizada, compuesta de hoja acabada en DM para pintar, premarco de pino, cerco de 90x30 mm. y jambas 90x10 mm. con marco en mismo acabado hoja. Pernos, cerradura, burlete de guillotina inferior y manilla. Elaborada en taller, con ajustes y fijación en obra. Totalmente montada y probada.*

*Supply and installation of Spigodoor block Sound Serie 32 dB approved of one leaf, with standardized dimensions, composed of leaf in DM for painting finish, subframe of pine, frame of 90x30 mm and jambs of 90x10 mm, with frame in the same finish of leaf Hinges, lock, inferior guillotine weather strip and handle. Material developed in workshop, with adjustments and on site fixation. Completely leveled and positioned.*



# Certificados Certificates

En la calidad final de un espacio constructivo también influye la gestión de la calidad en los procesos de producción. Por ello, Spigogroup desarrolla todos sus productos atendiendo a unos niveles de calidad que garanticen fiabilidad y confianza en todos sus proyectos.

The quality management in the production process influences in the final quality of a construction space. Therefore, Spigogroup develops its products to attend some standard of quality wich guarantee reliability and conficence into all projects.

Más de 30 años trabajando la madera han llevado a Spigogroup a respetarla, admirarla y ser conscientes de la importancia de establecer políticas para preservarla. Por ello, un excelente departamento de calidad dedicado a la mejora continua empresarial, avala su compromiso con el medio ambiente, el desarrollo sostenible de su actividad y su buena gestión empresarial como parte de la excelencia de sus productos y servicios.

Spigogroup has been working with wood over 30 years. Therefore, it has led us to admire and respect and be aware of the importance to stablish politics to preserve it. For this reason, an excellent Quality Department dedicated to the continuous business improvement, guarantees the commitment with the environment, sustainable development of its activity and its good business management like a part of excellence of its products and services.

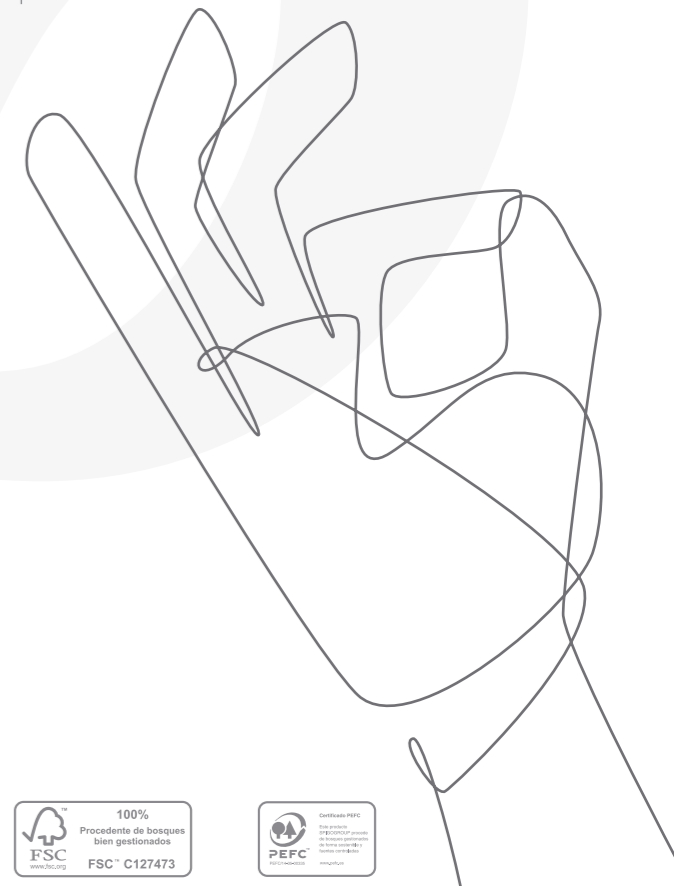

**spigo GROUP**<sup>®</sup>  
PROYECTOS EN MADERA

Polígono Industrial Cantabria II  
Calle Las Cañas 19  
26009 Logroño. La Rioja. Spain  
t. +34 941 244 777  
f. +34 941 261 580  
comercial@spigogroup.com  
export@spigogroup.com  
www.spigogroup.com

